

CHAMPIONNAT DU MONDE - ATHENES 1994

EN GARDE  
J-F NICAUD

EPREUVE PAR EQUIPES  
EPEE HOMMES

CLASSEMENT INITIAL

- 1 ALL
- 2 FRA
- 3 ITA
- 4 HON
- 5 ESP
- 6 RUS
- 7 SUE
- 8 CAN
- 9 EST
- 10 UKR
- 11 CUB
- 12 POL
- 13 KAZ
- 14 AUT
- 15 TCH
- 16 ROU
- 17 USA
- 18 COL
- 19 JAP
- 20 KOR
- 21 BUL
- 22 ARG
- 23 AFS
- 24 GBR
- 25 NOR
- 26 CHI
- 27 POR
- 28 DAN
- 29 KOW
- 30 AUS
- 31 YOU
- 32 GRE
- 33 TPE



CHAMPIONNATS DU MONDE D'ESCRIME SENIORS - ATHENES 1994

EPEE HOMMES PAR EQUIPES

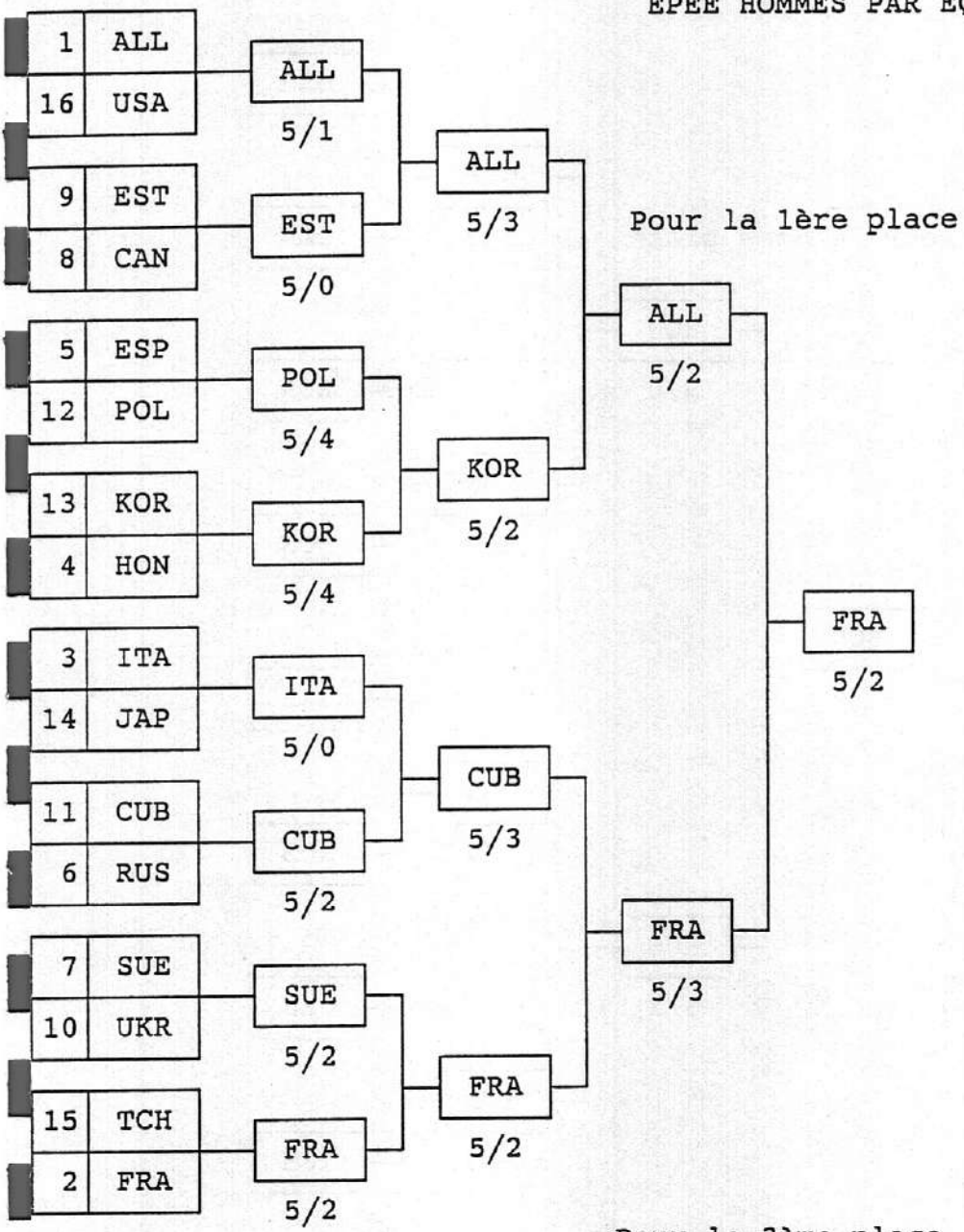

CLASSEMENT FINAL

1	FRA
2	ALL
3	KOR
4	CUB
5	SUE
6	EST
7	ITA
8	POL
9	HON
10	RUS
11	CAN
12	TCH
13	UKR
14	ESP
15	JAP
16	USA

Pour la 3ème place



TABLEAU 5-8

Pour la 7ème place

Pour la 5ème place

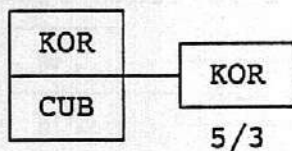
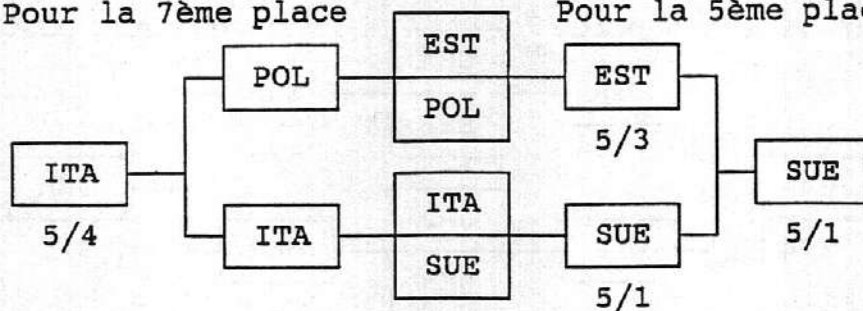

CHAMPIONNATS DU MONDE D'ESCRIME SENIORS - ATHENES 1994

EPEE HOMMES PAR EQUIPES

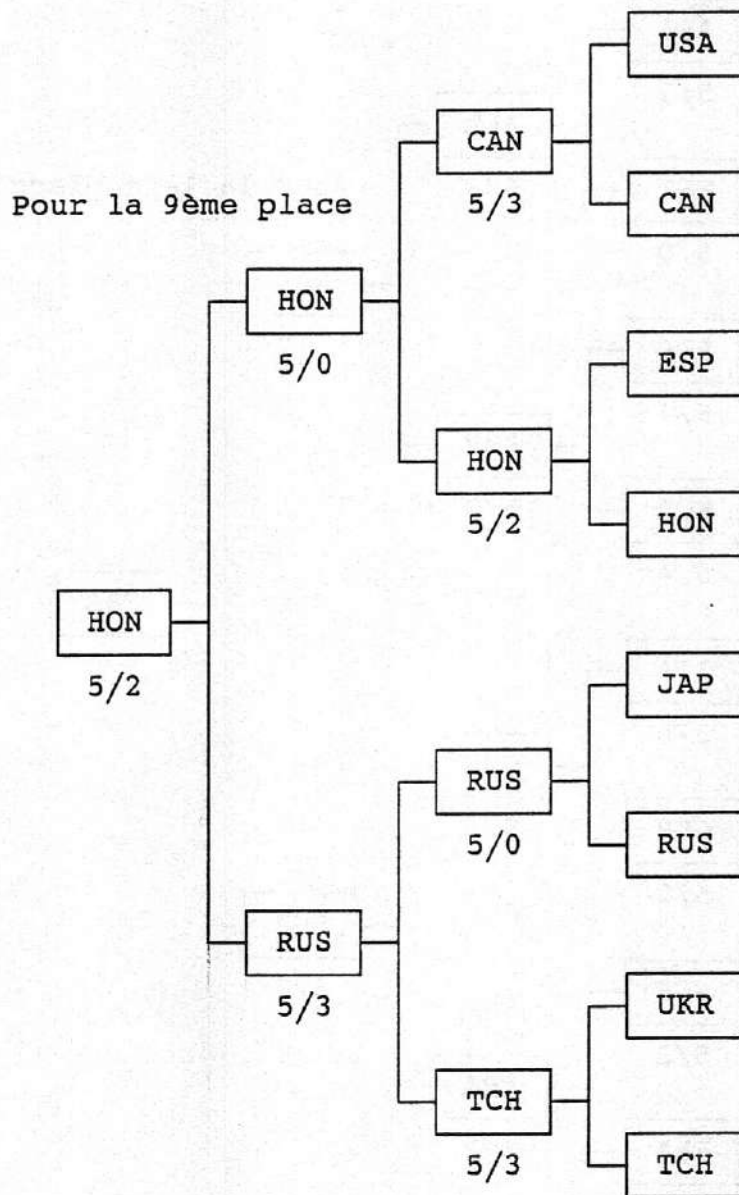

Pour la 11ème place



TABLEAU 13-16

Pour la 15ème place



Pour le 13ème place

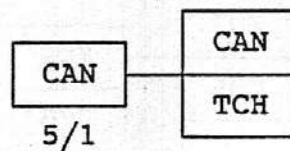
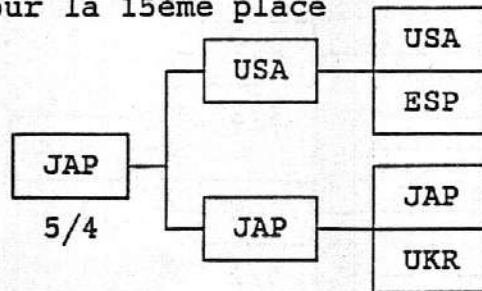
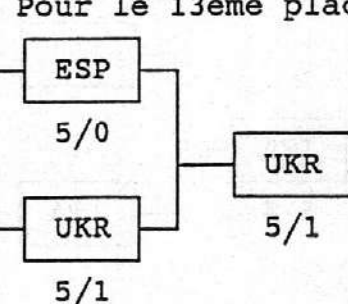





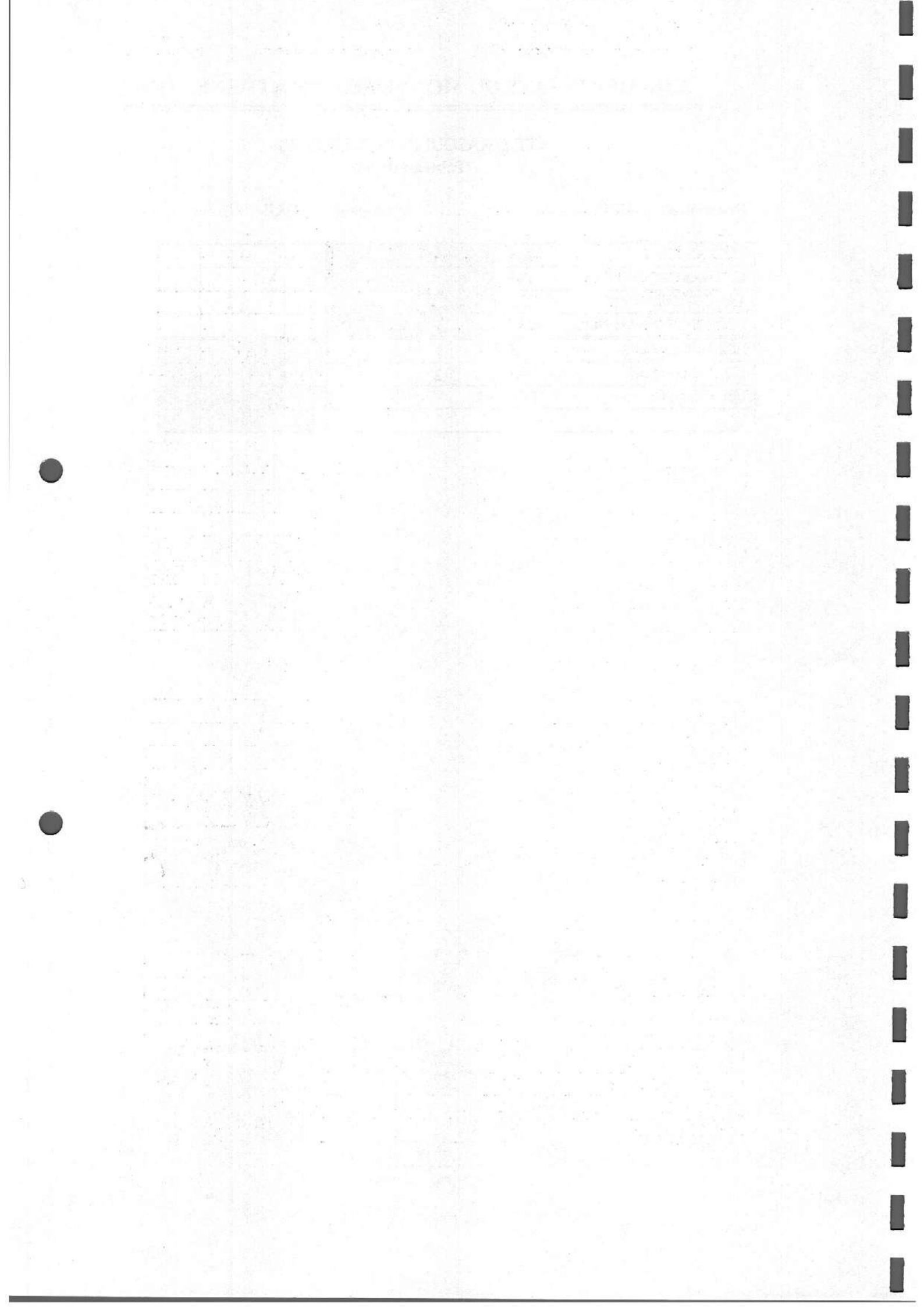

# CHAMPIONNATS DU MONDE SENIOR ATHENES 1994

## EPEE MASCULIN PAR EQUIPES

### Tableau de 32

Rencontre : ESP/DAN

Vainqueur : ESP 5/0

PENA Fernando	ESP						V	V	
MAROTO Raul	ESP						V		
LLORENS GONZALEZ	ESP						V	V	
FERNANDEZ Angel	ESP								
VON DER OSTEN Ha	DAN		3	2					
BONDE David	DAN	2							
WESTERMANN Henr	DAN	1		1					

Rencontre : BUL/POL

Vainqueur : POL 5/3

GALABOV Jordan	BUL					4	V	V	
NIKOLOV Ivan	BUL					2	V	4	
METCHKOV Ilia	BUL					3		2	
PETKOV Stojtcho	BUL								
GADOMSKI Witold	POL	V	V	V					
NAWROCKI Slavomi	POL	3	4						
JENDRYS Marek	POL	4	V	V					
STEPIEN Marek	POL								

Rencontre : HON/KOW

Vainqueur : HON 5/1

KOVACS Ivan	HON						4	V	
KULCSAR Krisztia	HON					V	V		
IMRE Gesa	HON					V		V	
TOTOLA Gabor	HON								
MALALLAH Hasan	KOW		3	1					
ABDELHADI Mohammed	KOW	V	3						
AL SHAMALI Rached	KOW	1		2					
AL MURDHI Mohedh	KOW								

Rencontre : AUS/ITA

Vainqueur : ITA 5/0

ROBINSON Seamus	AUS						2	4	
ARNOLD Scott	AUS					1			
WEYMOUTH Simon	AUS					3		2	
CHAN Tristan	AUS								
CUOMO Sandro	ITA		V	V					
MILANOLI Paolo	ITA	V							
RANDAZZO Maurizio	ITA	V		V					
MAZZONI Angelo	ITA								



# CHAMPIONNATS DU MONDE SENIOR ATHENES 1994

## EPEE MASCULIN PAR EQUIPES

### Tableau de 32

Rencontre : ALL/GRE

Vainqueur : ALL 5/0

SCHMITT Arnd	ALL						V	V	
STRZALKA Mariusz	ALL						V		
FLEGLER Michael	ALL						V	V	
BORRMANN Elmar	ALL								
GERMAKOPOULOS An	GRE		2	4					
TASSIOPOULOS Pet	GRE	3							
TSOKAS Petros	GRE	2		3					
DREPANOPOULOS Ni	GRE								

Rencontre : ROU/USA

Vainqueur : USA 5/3

POP Adrian	ROU					2	0		V
EPURESCU Georges	ROU					3	3		3
PANTELMON Gabri	ROU					V		V	
MILAN Corne	ROU								
BLOOM Tamir	USA	V	V	2					
NORMILE Jon	USA	V	V						
OSHIMA Marc	USA			0					
KELLY Christophe	USA	3	V						

Rencontre : EST/GBR

Vainqueur : EST 5/3

KAABERMA Kaido	EST					4	V	V	
KAJAK Andrus	EST					4	V	V	
LOIT Meelis	EST							V	
ZUIKOV Victor	EST					2			
HOWSER Chris	GBR	V	V		V				
POLLARD Anton	GBR	3	0						
LISTON George	GBR	4	3	3					
KIRBY Tom	GBR								

Rencontre : CAN/NOR

Vainqueur : CAN 5/1

CHOUINARD Jean-M	CAN						V	V	
NOWOSIELSKI Dan	CAN						V	V	
FRANCIS Allan	CAN							0	
BAKONYI David	CAN						V		
DANIELSEN Andrea	NOR		4		1				
NORDBY Jonas	NOR	3	0						
MORCH Klaus	NOR	1		V					
SKOGEN Pal	NOR								



# CHAMPIONNATS DU MONDE SENIOR ATHENES 1994

## EPEE MASCULIN PAR EQUIPES Tableau de 32

Rencontre : JAP/AUT

Vainqueur : JAP 5/2

NISHIGAKI Hitosi	JAP					V	V	2	
TANABE Norikazu	JAP					V	V		
MIYAMOTO Tomonoru	JAP							0	
YAMADA Makoto	JAP								
KAYSER Olivier	AUT		4		0				
ROBATSCH Markus	AUT	1	4						
GRAMMER Ralf	AUT	V			V				
HASLINGER Fritz	AUT	3							

Rencontre : ARG/CUB

Vainqueur : CUB 5/1

DI TELLA Rafael	ARG						V	0	
CUCCIOLI Hernan Carlos	ARG					4	4		
AGUERO Albino Ma	ARG					1		2	
GROUPIERRE Crist	ARG								
TREVEJO Iv	CUB		V	V					
CASTRO TERRY Laz	CUB	4							
BORIS BARRIENTOS	CUB	V			V				
AGUILERA VANCE C	CUB		V						

Rencontre : RUS/POR

Vainqueur : RUS 5/1

KOLOBKOV Pavel	RUS						V	V	
GLAZOUNOV Alexan	RUS					2	V		
BEKETOV Alexandr	RUS					V		V	
TCHERNYCHOV Alek	RUS								
FRAZAO Nuno	POR		V	1					
CORREIA Miguel	POR	1	4						
MELO Pedro	POR	3		5					

Rencontre : CHI/SUE

Vainqueur : SUE 5/3

XU Xuening	CHI					V	3	V	
XU Zhongzhu	CHI					3	2		3
WANG Qun	CHI					3		V	
VANKY Peter	SUE	3	V	V					
AHLGREN Mats	SUE	V	V						
GOMEZ Andres	SUE	2		2					
LUNDBLAD Tomas	SUE		V						

# CHAMPIONNATS DU MONDE SENIOR ATHENES 1994

## EPEE MASCULIN PAR EQUIPES Tableau de 32

Rencontre : UKR/AFS

Vainqueur : UKR 5/0

TICHKO Mikhail	UKR						V	V	
GORBATCHOUK Alek	UKR						V		
TATARKIN Alexand	UKR						V		V
AGUEEV Vitaly	UKR								
STEENKAMP Daniel	AFS		1	5					
RUDOLPH Gerhard	AFS	1							
VAN GARDEREN E.H.	AFS	2		0					
TORRENTE	AFS								

Rencontre : TCH/COL

Vainqueur : TCH 5/4

JECMINEK Roman	TCH					4	V	V	
FRAJBIS Vaclav	TCH					4	V	V	
DEPTA Ales	TCH					4		3	V
REZANKA Ota	TCH								
PAZ Juan Miguel	COL	V	V	V					
CARRASOUIL Car	COL	3	3						
RIVAS MauriciO	COL	2	5	V					
CONZALEZ Willian	COL			3					

Rencontre : FRA/YOU

Vainqueur : FRA 5/2

HENRY Jean-Miche	FRA					V	V	V	
SRECKI Eric	FRA					V	3		
LEROUX Robert	FRA					4		V	
FAGET Herve	FRA								
TANASIJEVIC Drag	YOU	1	5	V					
NECKOVIC Vlada	YOU	3	V						
BARALIC Damir	YOU	4		3					
DUMITROV Veselko	YOU								

Rencontre :

Vainqueur :



# CHAMPIONNATS DU MONDE SENIOR ATHENES 1994

## EPEE MASCULIN PAR EQUIPES

Tableau de 16

Rencontre : ALL/USA

Vainqueur : ALL 5/1

SCHMITT Arnd	ALL						V	V	
STRZALKA Mariusz	ALL						V	V	
FLEGLER Michael	ALL						V		2
BORRMANN Elmar	ALL								
BLOOM Tamir	USA		4	0					
NORMLE Jon	USA	3	0						
KELLY Christophe	USA	4		V					
OSHIMA Marc	USA								

Rencontre : EST/CAN

Vainqueur : EST 5/0

KAABERMA Kaido	EST						V	V	
KAJAK Andrus	EST						V		
LOIT Meelis	EST						V		V
ZUIKOV Victor	EST								
NOWOSIELSKI Dan	CAN		4	2					
BAKONYI David	CAN	1							
CHOUNARD Jean-M	CAN	4		3					
FRANCIS Allan	CAN								

Rencontre : POL/ESP

Vainqueur : POL 5/4

GADOMSKI Witold	POL						V	V	3
JENDRYS Marek	POL						5	2	
NAWROCKI Slavomi	POL						V	V	V
STEPIEN Marek	POL								3
PENA Fernando	ESP	2	V	3					
MAROTO Raul	ESP	2	V						
FERNANDEZ Angel	ESP	V	V	4					
LLORENS GONZALEZ	ESP			4					

Rencontre : HON/KOR

Vainqueur : KOR 5/4

KOVACS Ivan	HON							1	2
KULCSAR Krisztia	HON						V	V	V
IMRE Gesa	HON						3	3	V
TOTOLA Gabor	HON						3		
LEE Sang Ki	KOR		2	V	V				
LEE SANG-Yup	KOR	V	3	V					
KU Kyo-Dong	KOR	V	0	2					
YOON Won-Jin	KOR								



# CHAMPIONNATS DU MONDE SENIOR ATHENES 1994

## EPEE MASCULIN PAR EQUIPES

Tableau de 16

Rencontre : JAP/ITA

Vainqueur : ITA 5/0

NISHIGAKI Hitosi	JAP						1	2	
MIYAMOTO Tomonoru	JAP						1		
YAMADA Makoto	JAP						2	2	
TANABE Norikazu	JAP								
MAZZONI Angelo	ITA		V	V					
RANDAZZO Maurizio	ITA	V							
CUOMO Sandro	ITA	V		V					
MILANOLI Paolo	ITA								

Rencontre : RUS/CUB

Vainqueur : CUB 5/2

KOLOBKOV Pavel	RUS						3	V	4
GLAZOUNOV Alexan	RUS						1	3	
BEKETOV Alexan	RUS						V		3
TCHERNYCHOV Alek	RUS								
TREVEJO PEREZ Ivan	CUB	V	V	4					
AGUILERA VANCE Ces	CUB	4	V						
BORIS BARRIENTOS Ca	CUB	V		V					
CASTRO TERRY Lazaro	CUB								

Rencontre : UKR/SUE

Vainqueur : SUE 5/2

TICHKO Mikhail	UKR						3	4	V
GORBATCHOUK Aleksei	UKR						1		
TATARKIN Alexan	UKR						0		3
AGUEEV Vitaly	UKR							V	
VANKY Peter	SUE	V	V	V					
LUNDBLAD Tomas	SUE	V			3				
GOMEZ Andres	SUE	0		V					
AHLGREN Mats	SUE								

Rencontre : FRA/TCH

Vainqueur : FRA 5/2

HENRY JEAN-Michel	FRA						V	4	4
SRECKI Eric	FRA						V	V	
LEROUX Robert	FRA						V		V
FAGET Herve	FRA								
JECMINEK Roman	TCH	2	2	1					
DEPTA Ales	TCH	V	1						
FRAJBIS Vaclav	TCH	V		3					
REZANKA Ota	TCH								

# CHAMPIONNATS DU MONDE SENIOR ATHENES 1994

## EPEE MASCULIN PAR EQUIPES

### Tableau de 8

Rencontre : FRA/SUE

Vainqueur : FRA 5/2

HENRY Jean-Michel	FRA					V	3	V	
SRECKI Eric	FRA					1	V		
LEROUX Robert	FRA					V		V	
FAGET Herve	FRA								
VANKY Peter	SUE	5	V	3					
AHLGREN Mats	SUE	V	1						
LUNDBLAD Tomas	SUE	1		3					
GOMEZ Andres	SUE								

Rencontre : ALL/EST

Vainqueur : ALL 5/3

SCHMITT Arnd	ALL					V	3	V	
STRZALKA Mariusz	ALL					V	V	V	
FLEGLER Michael	ALL					4		3	
BORRMANN Elmar	ALL								
KAABERMA Kaido	EST	2	1	V					
LOIT Meelis	EST	V	2						
KAJAK Andrus	EST	1	3	V					
ZUIKOV Victor	EST								

Rencontre : ITA/CUB

Vainqueur : CUB 5/3

MAZZONI Angelo	ITA					1	V	V	
CUOMO Sandro	ITA					3	2		
RANDAZZO Maurizio	ITA					4		V	
MILANOLI Paolo	ITA							2	
TREVEJO PEREZ Ivan	CUB	V	V	V					
AGUILERA VANCE Ce	CUB	2	V						
BORIS BARRIENTOS	CUB	1		3	V				
CASTRO TERRY Laz	CUB								

Rencontre : KOR/POL

Vainqueur : KOR 5/2

LEE Sang-Yup	KOR					V	V		V
LEE Sang Ki	KOR					1	V		
YOON Won-Jin	KOR					4		V	
KU Kyo-Dong	KOR								
GADOMSKI Witold	POL	4	V	V					
NAWROCKI Slavomir	POL	3	4						
JENDRYNS Marek	POL			4					
STEPIEN Marek	POL	5							





# CHAMPIONNATS DU MONDE SENIOR ATHENES 1994

## EPEE MASCULIN PAR EQUIPES Tableau de Classement du 9<sup>eme</sup> a la 16<sup>eme</sup> PLACES

Rencontre : JAP/RUS

Vainqueur : RUS 5/0

NISHIGAKI Hitosi	JAP						3	2	
TANABE Norikazu	JAP						2		
YAMADA Makoto	JAP						2	4	
MIYAMOTO Tomonoru	JAP								
GLAZOUNOV Alex	RUS		V	V					
TCHERNYCHOV Alek	RUS	V							
BEKETTOV Alex	RUS	V		V					
KOLOBKOV Pavel	RUS								

Rencontre : USA/CAN

Vainqueur : CAN 5/3

BLOOM Tamir	USA						4	3	2
NORMILE Jon	USA						V	2	2
KELLY Christopher	USA						V		V
OSHIMA Marc	USA								
NOWOSIELSKI Dan	CAN	V	4	4					
BAKONYI David	CAN	V	V						
FRANCIS Allan	CAN	V	V	3					
CHOUINARD Jean-Marc	CAN								

Rencontre : ESP/HON

Vainqueur : HON 5/2

PENA Fernando	ESP						2	2	5
FERNANDEZ Angel	ESP						2	V	
MAROTO Raul	ESP						V		2
LLORENS GONZALEZ	ESP								
KOVACS Ivan	HON	V	V	4					
IMRE Geza	HON	V	3						
KULCSAR Krisztian	HON	V		V					
TOTOLA Gabor	HON								

Rencontre : TCH/UKR

Vainqueur : TCH 5/3

DEPTA Ales	TCH						3	V	3
JECMINEK Roman	TCH						V	V	V
FRAJBIS Vaclav	TCH						3		V
REZANKA Ota	TCH								
AGUEEV Vitaly	UKR	V	3	V					
GORBATCHOUK Aleksei	UKR	3	4						
TATARKIN Alexandre	UKR	V	4	4					
TICHKO Mikhail	UKR								

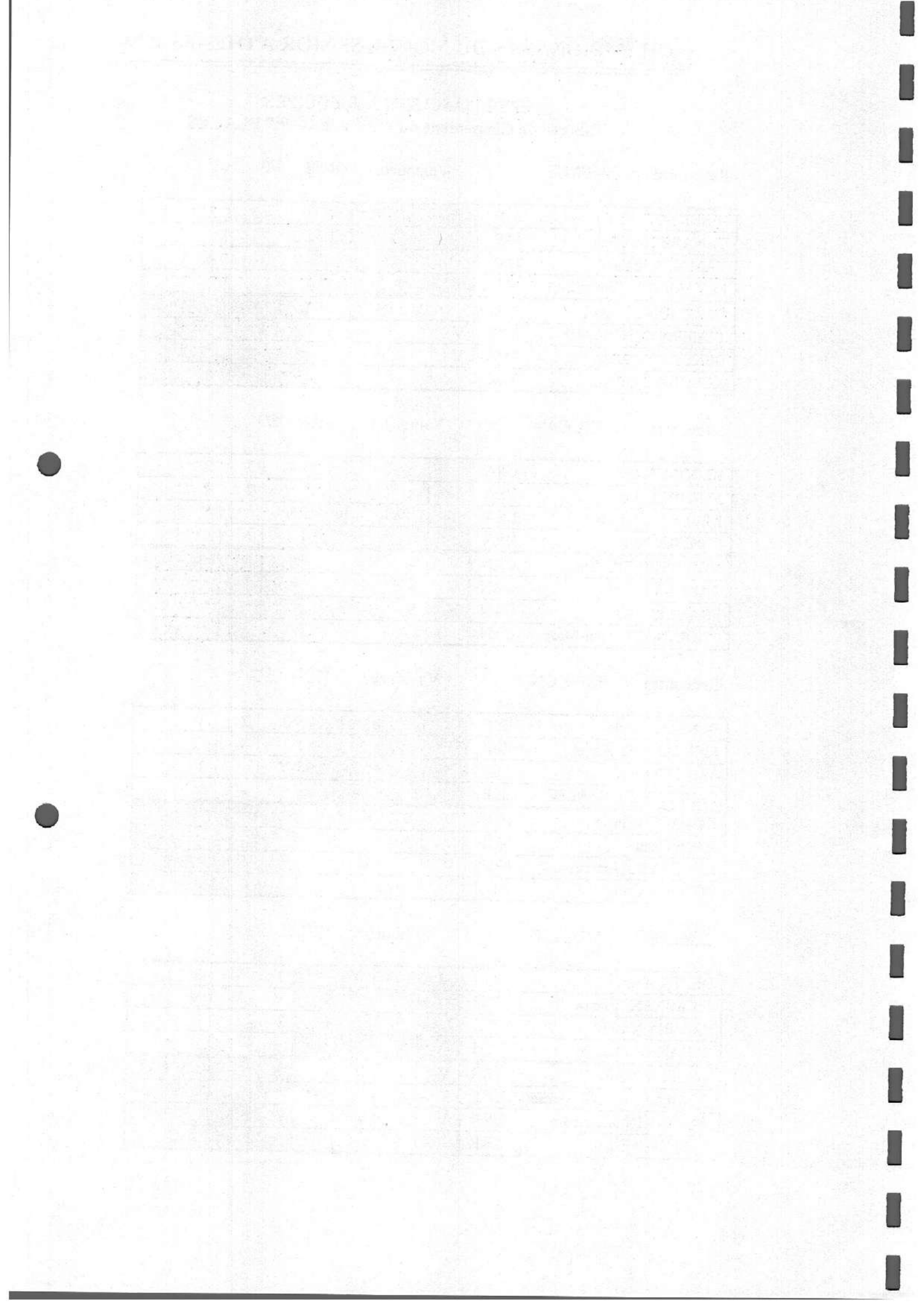

# CHAMPIONNATS DU MONDE SENIOR ATHENES 1994

## EPEE MASCULIN PAR EQUIPES Tableau de Classement du 13<sup>eme</sup> a la 16<sup>eme</sup> PLACES

Rencontre : USA/ESP

Vainqueur : ESP 5/0

BLOOM Tamir	USA					4	2	
NORMILE Jon	USA					3		
KELLY Christopher	USA						1	
OSHIMA Marc	USA					0		
FERNANDEZ Angel	ESP		V		V			
LLORENS GONZALEZ	ESP	V						
MAROTO Raul	ESP	V		V				

Rencontre : JAP/UKR

Vainqueur : UKR 5/1

MIYAMOTO Tomonoru	JAP					V	2	
TANABE Norikazu	JAP					0	3	
NISHIGAKI Hitosi	JAP					4		3
YAMADA Makoto	JAP							
AGUEEV Vitaly	UKR		V	V				
GORBATCHOUK Alek	UKR	4	V					
TATARKIN Alexan	UKR	V		V				
TICHKO Mikhail	UKR							



# CHAMPIONNATS DU MONDE SENIOR ATHENES 1994

## EPEE MASCULIN PAR EQUIPES 15<sup>eme</sup> PLACE

Rencontre : JAP/USA

Vainqueur : JAP 5/4

MIYAMOTO Tomonoru	JAP						3	3	
YAMADA Makoto	JAP					V	3	V	
NISHIGAKI Hitosi	JAP					V	V	V	
TANABE Norikazu	JAP					4			
BLOOM Tamir	USA		5	4	V				
NORMILE Jon	USA	V	V	2					
OSHIMA Marc	USA	V	3	4					
KELLY Christopher	USA								

## EPEE MASCULIN PAR EQUIPES 13<sup>eme</sup> PLACE

Rencontre : ESP/UKR

Vainqueur : UKR 5/1

FERNANDEZ Angel	ESP						4	V	
LLORENS GONZALEZ	ESP					1	4		
MAROTO Raul	ESP					2		2	
PENA Fernando	ESP								
AGUEEV Vitaly	UKR		V	V					
GORBATCHOUK Aleksei	UKR	V	V						
TATARKIN Alexan	UKR	4		V					

# CHAMPIONNATS DU MONDE SENIOR ATHENES 1994

## EPPE MASCULIN PAR EQUIPES Tableau de Classement du 9<sup>eme</sup> a la 12<sup>eme</sup> PLACES

Rencontre : HON/CAN

Vainqueur : HON 5/0

KOVAKS Ivan	HON						V	V	
IMRE Geza	HON						V	V	
KULCSAR Krisztian	HON							V	
TOTOLA Gabor	HON								
CHOUINARD Jean-Marc	CAN		4						
BAKONYI David	CAN	3	0						
FRANCIS Allan	CAN	3		1					
NOWOSIELSKI Dan	CAN								

Rencontre : RUS/TCH

Vainqueur : RUS 5/3

GLAZOUNOV Alexan	RUS						V	V	2
TCHERNYCHOV Alek	RUS						4	V	V
BEKETOV Alexan	RUS						2		V
KOLOBKOV Pavel	RUS								
JECMINEK Roman	TCH	3	V	V					
REZANKA Ota	TCH	3	1						
FRAJBIS Vaclav	TCH	V	4	1					
DEPTA Ales	TCH								

# CHAMPIONNATS DU MONDE SENIOR ATHENES 1994

## EPEE MASCULIN PAR EQUIPES 11<sup>eme</sup> PLACE

Rencontre : CAN/TCH

Vainqueur : CAN 5/1

CHOUINARD Jean-Marc	CAN						V	V	
BAKONYI David	CAN						V	V	
FRANCIS Allan	CAN						V		4
NOWOSIELSKI Dan	CAN								
JECMINEK Roman	TCH		3	2					
FRAJBIS Vaclav	TCH	2	2						
DEPTA Ales	TCH	2		V					
REZANKA Ota	TCH								

## EPEE MASCULIN PAR EQUIPES 9<sup>eme</sup> PLACE

Rencontre : RUS/HON

Vainqueur : HON 5/2

GLAZOUNOV Alexan	RUS					3	3	V	
TCHERNYCHOV Alek	RUS					3	3		
BEKETOV Alexan	RUS					V		1	
KOLOBKOV Pavel	RUS								
KOVACS Ivan	HON	V	V	4					
KULCSAR Krisztian	HON	V	V						
IMRE Geza	HON	4		V					
TOTOLA Gabor	HON								



# CHAMPIONNATS DU MONDE SENIOR ATHENES 1994

## EPEE MASCULIN PAR EQUIPES Tableau de Classement du 5<sup>eme</sup> a la 8<sup>eme</sup>

Rencontre : EST/POL

Vainqueur : EST 5/3

KAABERMA Kaido	EST					V	3	V	
KAJAK Andrus	EST					V	2	V	
LOIT Meelis	EST					V		5	
ZUIKOV Victor	EST								
GADOMSKI Witold	POL	2	3	4					
NAWROCKI Slavomir	POL	V	V						
STEPIEN Marek	POL	4	2	V					
JENDRYS Marek	POL								

Rencontre : SUE/ITA

Vainqueur : SUE 5/1

VANKY Peter	SUE						V	V	
LUNDBLAD Tomas	SUE					4	V		
GOMEZ Andres	SUE					V		V	
AHLGREN Mats	SUE								
MAZZONI Angelo	ITA		V	4					
RANDAZZO Maurizio	ITA	4	2						
MILANOLI Paolo	ITA	1		3					
CUOMO Sandro	ITA								

# CHAMPIONNATS DU MONDE SENIOR ATHENES 1994

## EPEE MASCULIN PAR EQUIPES 7<sup>eme</sup> PLACE

Rencontre : POL/ITA

Vainqueur : ITA 5/4

STEPIEN Marek	POL					4	1	V	
JENDRYNS Marek	POL					V	V	2	
NAWROCKI Slavomir	POL					2	4	V	
GADOMSKI Witold	POL								
MAZZONI Angelo	ITA	V	3	V					
CUOMO Sandro	ITA	V	4	V					
RANDAZZO Maurizio	ITA	3	V	3					
MILANOLI Paolo	ITA								

## EPEE MASCULIN PAR EQUIPES 5<sup>eme</sup> PLACE

Rencontre : SUE/EST

Vainqueur : SUE 5/1

VANKY Peter	SUE						V	V	
AHLGREN Mats	SUE					V	V		
LUNDBLAD Tomas	SUE							2	
GOMEZ Andres	SUE					V			
KAABERMA Kaido	EST		2		2				
LOIT Meelis	EST	5	0						
KAJAK Andrus	EST	2		V					
ZUIKOV Victor	EST								

# CHAMPIONNATS DU MONDE SENIOR ATHENES 1994

## EPEE MASCULIN PAR EQUIPES Tableau de DEMI FINALE

Rencontre : KOR/ALL

Vainqueur : ALL 5/2

LEE Sang-Yup	KOR					3	3	V	
LEE Sang Ki	KOR					4	V		
YOON Won-Jin	KOR					2		4	
KU Kyo-Dong	KOR								
SCHMITT Arnd	ALL	V	V	V					
FLEGLER Michael	ALL	V	1						
STRZALKA Mariusz	ALL	3		V					
BORRMANN Elmar	ALL								

Rencontre : FRA/CUB

Vainqueur : FRA 5/3

HENRY Jean-Michel	FRA					3	V	V	
SRECKI Eric	FRA					4	1		V
LEROUX Robert	FRA					V		V	
FAGET Herve	FRA								
TREVEJO PEREZ Ivan	CUB	V	V	3					
AGUILERA VANCE Ce	CUB	2	V						
BORIS BARRIENTOS	CUB	2		4					
CASTRO TERRY La	CUB	1							



# CHAMPIONNATS DU MONDE SENIOR ATHENES 1994

## EPEE MASCULIN PAR EQUIPES 3<sup>eme</sup> PLACE

Rencontre : KOR/CUB

Vainqueur : KOR 5/3

LEE Sang Ki	KOR					V	3	V	
LEE Sang-Yup	KOR					V	3	V	
KU Kyo-Dong	KOR					1		V	
YOON Won-Jin	KOR								
TREVEJO PEREZ Ivan	CUB	5	3	V					
AGUILERA VANCE Ces	CUB	V	V						
BORIS BARRIENTOS Ca	CUB	2	3	4					
CASTRO TERRY Lazaro	CUB								

## EPEE MASCULIN PAR EQUIPES FINALE

Rencontre : ALL/FRA

Vainqueur : FRA 5/2

SCHMITT Arnd	ALL					0	V	0	
STRZALKA Mariusz	ALL					V	3		
FLEGLER Michael	ALL					2		5	
BORRMANN Elmar	ALL								
HENRY Jean-Michel	FRA	V	4	V					
LEROUX Robert	FRA	2	V						
SRECKI Eric	FRA	V		V					
FAGET Herve	FRA								